

Shermann M20

Preliminary information

Shermann's M20 is an ultra-compact, high power 12"/1.4" coaxial, low profile stage wedge monitor weighing in at 14.1kgs.

The 40° x 60° dispersion from the 1.4" exit integral horn assembly allows monitor engineers to set higher than normal levels when necessary with minimal spill to other artists.

The **M20** also incorporates "Link-Onwards", Sherman's new facility to enable the connection of three further **M20** from the four-core input cable that supplies monitor 1. (See diagrams on page 2 & 3)

"Link-Onwards" uses standard 4 core input cables for both channels whilst 2 core may be used for links - no special adaptors are needed as all inputs and outputs are on pins 1+1-.

As a further advantage the **M20** is smaller and lighter than virtually all other competitive products.



The M20 cabinet.

Built from high grade Eastern European birch plywood the **M20** has been carefully designed to provide an appropriate listening angle for artists standing at a microphone stand or seated playing keyboards or drums.

Connectors have been thoughtfully linked using our new "Link Forward" facility to allow run through between cabinets without the use of an adapter.

An insert handle is supplied on the top rear edge of the enclosure.

The cabinet shell is finished in Sherman's ultra durable TPC material for years of hard work.

Replaceable plywood skids are also fitted.

The 12" bass/low-mid section.

With excellent power handling and high efficiency this section of the drive unit features a rather unusual 76mm voice coil driving a curved cone with a very low moving mass.

This results are truly spectacular.

With a conservative AES power handling of 400 watts and an efficiency of close to 99dB the 12" driver is capable of high pressure levels.

The 1.4" exit upper-mid/HF section.

From the 12" section all frequencies above 1200Hz are handled by the 1.4" exit compression driver.

Featuring a 76mm voice coil this driver has a lightweight diaphragm manufactured from pure titanium.

The driver exits through a centrally loaded horn assembly offering 40° x 60° dispersion in the standard wedge position.

Low-Profile Versatility.

The **M20** is a powerful stage monitor; using its steep 35° angle it can be placed close to microphone stands for the most useful upward angle of projection thereby reducing spill to other performers.

Exterior fittings

Handle (top)

Recessed grab type

Finish

TPC (Textured Protective Coating)

TRC water based paint available

Skids

Bottom and rear mounted easily replaced 15mm plywood skids

Stand mount (to order)

Construction

Cabinet shell

15mm & 18mm multi-laminate fully braced European birch plywood.

Baffle assembly

18mm multi-laminate Scandinavian birch plywood.

Connections

Speakon NLT4 x 2

Inputs use pin 1+ hot / pin 1- cold

Our *Link-Onwards* facility to pins 1+ 1- on the two NL4 outputs is fed from pins 2+ 2- on the NLT4 input connectors.

Output for the *Link-Onwards* facility via pins 1+ 1- on NL4 output connectors.

See diagram on page 2 for brief explanation or page 3 where the *Link-Onwards* facility is described in detail.

Connector plates are normally located at the lower rear of the M20 however, these may be installed elsewhere to order.

Crossover frequencies

High pass (full range mode)

70Hz 4th/8th order Linkwitz-Riley or Butterworth filtering

* Options must be requested at time of ordering.

For optimum performance and system protection we recommend the use of a digital loudspeaker management unit within systems incorporating the M20.

Ashly, BSS, DBX, Klark-Teknik, Xilica and XTA offer suitable models which may be loaded with preset configurations to enable successful operation within any Sherman system.

The foam front used in this cabinet is not fire retardant.

Shermann M20

Preliminary information

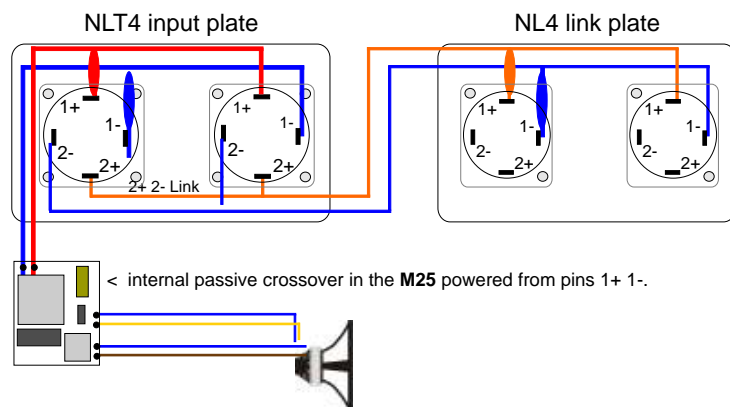
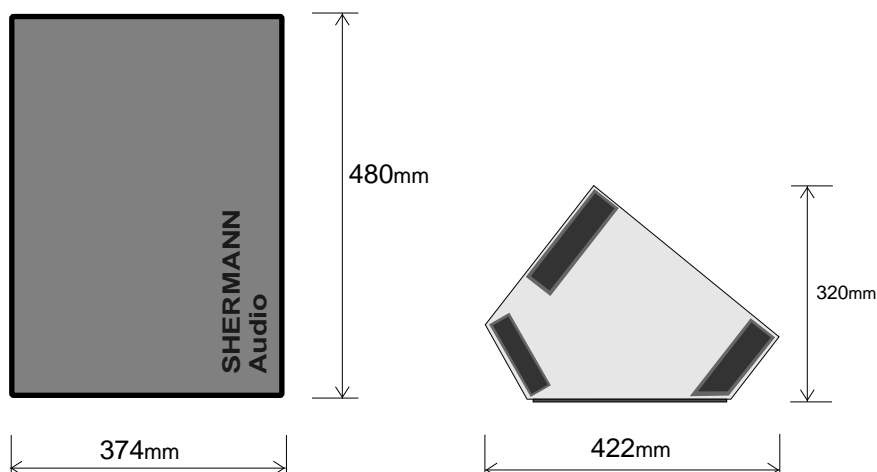

M20 & M25 Link-Onwards facility

We've arranged the **M25** to have two input and two output connectors.

The NLT4 connectors are inputs/links for channel 1 where pins **1+ 1-** feed the internal components of the **M20/M25** and the smaller NLT4 sockets are links fed via pins **2+ 2-** to further M25 cabinets.

Essentially this system, when used with care, will allow cabinet 1 in the chain to also feed cabinet 2 via a four core cable.

Cabinets 3 and 4 are connected to the link socket on cabinet 1 or cabinet 2 via two core cables wired **1+ 1-** at both ends delivering an entirely separate source from pins **2+ 2-** on your amplifier patch panel.

This linking system allows all cabinets in use to operate from cables using pins **1+ 1-** with no need for special pin changing cables.

The diagram above shows the Link-Onwards connections in detail.

Speaker Cables

We recommend the use of **2.5mm²** or **4mm²** OFC cabling with all Sherman full range cabinets.

Wherever possible, cable lengths should not exceed **5 metres** for 4 ohm loading (*2 x 8ohm M20 in parallel*); cabinet link cables should not exceed 2 metres.

Please note

We would like to draw your attention to the likelihood of hearing damage from prolonged exposure to high sound pressure levels.

Care should be taken when using cabinets in close proximity to the audience, musicians or artists.

For further information on the safe operation of any Sherman product please fax, call or email us - contact details are shown below.

The information within this data sheet is accurate and correct at the time of publication.

It is recommended that all technical information is verified with the company before inclusion in quotations or tender documents.

The company will not be held responsible for losses or difficulties arising from errors, changes or omissions.

Tel: +44 (0)1686 622 997

Fax: +44 (0)1686 623 233

Email: info@shermann.com

Web: www.shermann.com

All data, images & product design; © Ken Hughes 2010. **Shermann** is a registered trade mark used by S.P.A. Systems Ltd

Technical Specifications

System

Format	2 way Passive
Network	PCN3
Nom' impedance	8 ohms
Hi-pass filter (-3dB point)	70Hz / 4th order
Rec' amp' power @ 8 ohm	400 watts rms
Continuous Programme	800 watts

Performance

Sensitivity @ 1w/1m	99 dB
Output at rated power	126 dB @ 1m
Frequency response	60 Hz - 18.5 KHz
Dispersion > 1200 KHz	40° x 60°

Drive unit - LF

Drive unit size	315 mm / 12.1"
Voice coil diameter	76 mm / 3"
Chassis	cast aluminium
Magnet	neodymium
Mounting	6mm caphead bolts x 4

Drive unit - HF

Drive unit exit	36 mm / 1.4"
Voice coil diameter	76 mm / 3"
Magnet	neodymium
Diaphragm	titanium
Mounting	6 mm x 4

Dimensions

Width	480 mm (18.9")
Depth (on stage)	422 mm (16.65")
Apex height *	305 mm (12.00")
External volume	46.8 lts (1.68 ft ³)
Weight	14.1 Kgs (31.1 lbs)

* Apex height with skids 320 mm (12.62")

* Options must be requested at time of ordering.

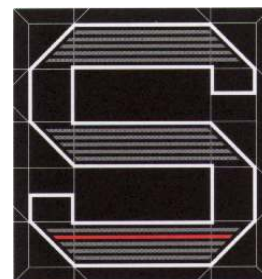

Shermann

The M Series

Shermann M20 & M25 wedges



“Link-Onwards” facility.

Here we explain the purpose and operation of Shermann’s “Link-Onwards” facility.

It involves the use of four NL4 style connectors per cabinet however, we’ve simplified connections through the use of a pair of NLT4 for inputs with the original NL4 connectors in pairs for the outputs of ch2.

The basics of the system are shown in the diagram below and at the foot of the page we’ve included a cabinet connection scenario detailing how this method should save rigging time and cable quantity.

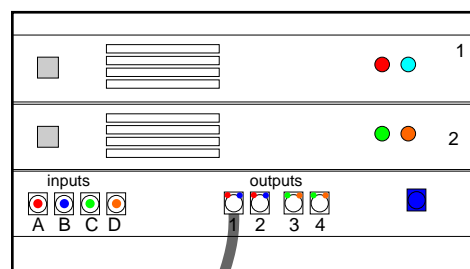
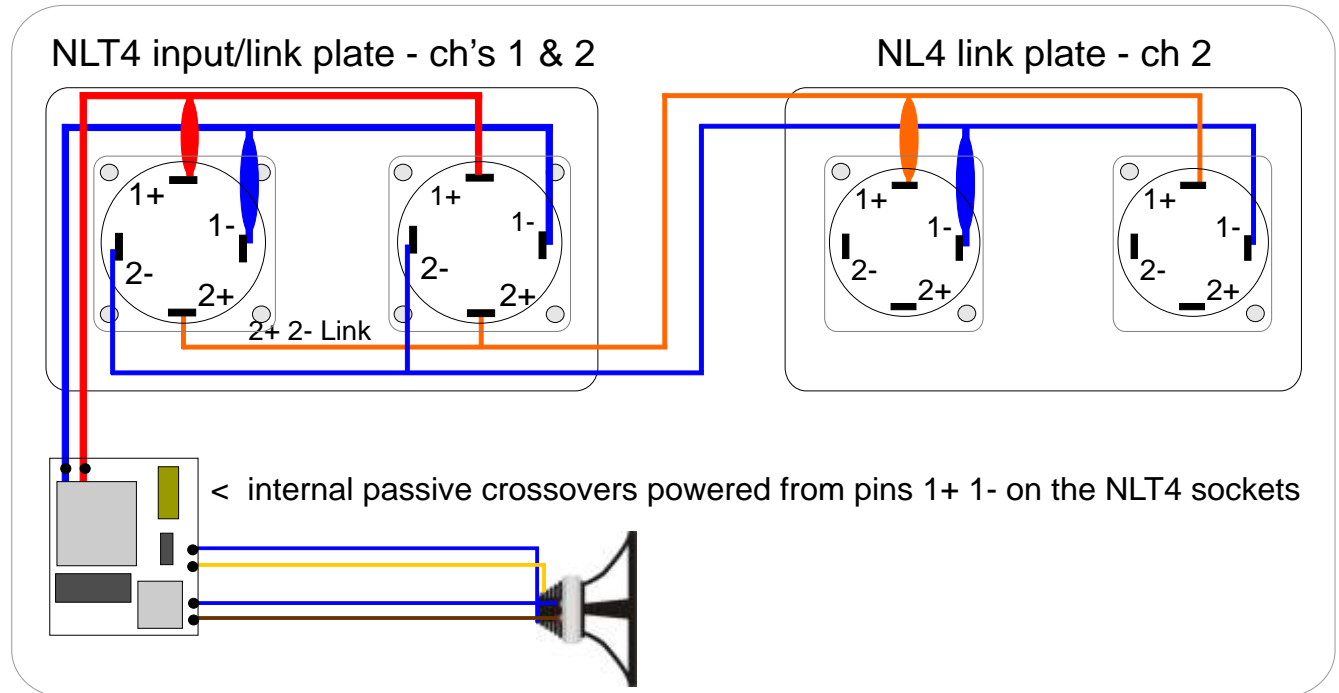

4 core cables

In this diagram we have assumed 4 ohm minimum loading throughout however, the **M Series** “Link-Onwards” principle will operate in the same manner for amplifiers capable of handling 2 ohm loads.

Whilst “Link-Onwards” connections are simple care should be exercised when this system is being used by inexperienced operators.

Always take speaker supply from one point and do not attempt to loop cables back to the source.

4 core cables may be used for link cables to monitors 3 & 4 as there are no connections to pins 2+ 2- on the NL4 outputs.

It should be noted that all connections to cabinets fitted with the “Link-Onwards” facility are made using conventionally wired speaker cables.

2 core cables wired
pin 1+ 1- at both ends

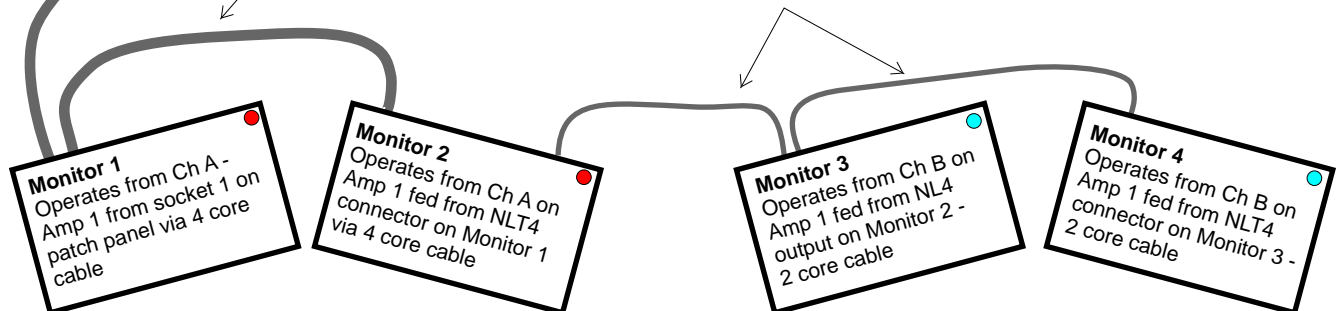

Monitor 1
Operates from Ch A -
Amp 1 from socket 1 on
patch panel via 4 core
cable

Monitor 2
Operates from Ch A on
Amp 1 fed from NLT4
connector on Monitor 1
via 4 core cable

Monitor 3
Operates from Ch B on
Amp 1 fed from NL4
output on Monitor 2 -
2 core cable

Monitor 4
Operates from Ch B on
Amp 1 fed from NLT4
connector on Monitor 3 -
2 core cable